



Business Mail Rate card

**Royal Mail Business Mail[®]
and Business Mail 1st Class**

March 2017

Helping your business thrive and prosper

In a digital world, consumers place a high value on mail. We believe in the power of 1 to 1 communications to build customer relationships. Technology has transformed communications, but the core strengths of mail have endured and in some cases grown even stronger. Mail helps you connect with your customers and attract new customers in a way that few other channels can, especially when combined with digital.

Royal Mail is the UK's designated Universal Postal Service Provider, supporting customers, businesses and communities across the country. We are the only company that has the capability to deliver a 'one-price-goes-anywhere', six-days-a-week service on a range of letters and parcels to more than 29 million addresses across the UK.

Online Price Calculator

Use our online price calculator to find the best options for your mailing. There's also a downloadable excel version.

royalmailtechnical.com/calculator

For other prices such as stamps, franking, parcels and international please visit:

royalmail.com/prices2017

From 27 March 2017 prices in this rate card can be found at royalmail.com/business-mail

Although correct at the time this price guide was produced (March 2017), postal prices, fees and other conditions are subject to revision from time to time and services may need to be added or withdrawn.

Up-to-date information may be obtained by visiting royalmail.com

Contents

Know your formats	4
<hr/>	
Business Mail 1st Class & Business Mail	
<hr/>	
Unsorted: Full prices and per gram increments	5
Low Sort: Full prices and per gram increments	8
Calculating the price of your mailing	10
High Sort: Full prices and per gram increments	11
Calculating the price of your mailing	13
<hr/>	
Adjustment charges	14
<hr/>	

Know your formats

Here are the formats we use to work out the postage. Each format has its own size and weight limits. The illustrations below will help you work out which format your item will fall into.

Letter Up to 100g

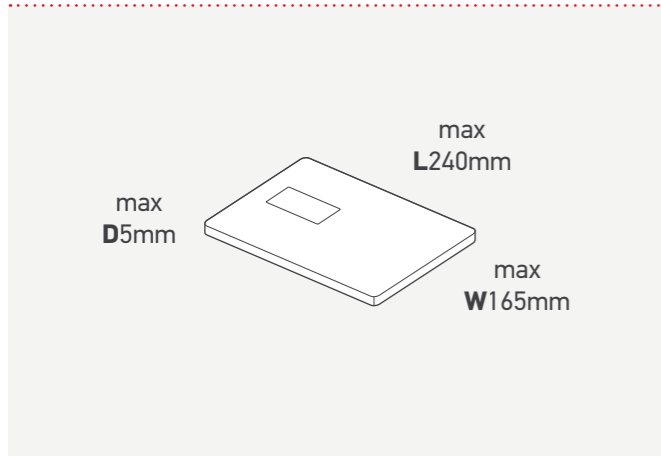

Large Letter Up to 750g

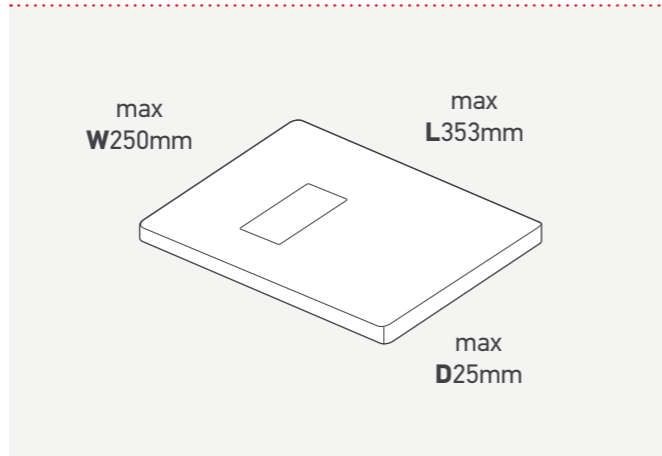

Large Letter – machine readable Up to 750g

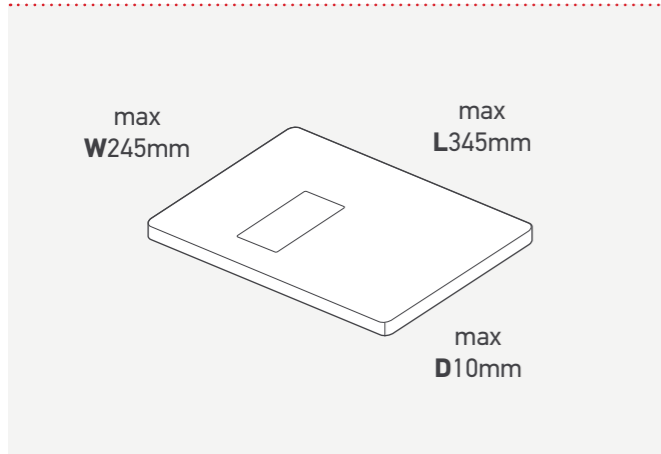

There is no Parcel option in Business Mail and goods are not permitted in Business Mail Large Letters. For information on Parcels services please visit royalmail.com/parcels

Business Mail

Unsorted

Table 1 – Letter: Standard unsorted options

Delivery Speed	Option	Product Code	Weight up to and including	Number of items per sales order				
				0-999	1,000-2,499	2,500-9,999	10,000-24,999	25,000+
1st Class	Standard	STL	100g	54.0p	52.9p	51.6p	50.5p	49.4p
	Account*	UNA	100g	53.0p	51.9p	50.6p	49.6p	48.5p
2nd Class	Standard	STL	100g	38.0p	37.4p	36.6p	35.8p	35.0p
	Account*	UNB	100g	37.0p	36.4p	35.7p	34.9p	34.1p

Prices in this table exclude VAT, which is charged at the standard rate.
*Available from 27th March 2017.

For further information on the new options for 27 March visit royalmail.com/barcodesavings

Unsorted

Table 2 – Letter: Machine-readable unsorted options

Delivery Speed	Product Code	Option	Weight up to and including	Number of items per sales order†					
				1-499	500-999	1,000-2,499	2,500-9,999	10,000-24,999	25,000+
1st Class	EBR	Mailmark	100g	N/A	45.0p	44.3p	43.4p	42.5p	41.6p
	CLA	Advanced	100g	52.0p	46.3p	45.6p	44.7p	43.8p	42.8p
	CL3	OCR	100g	N/A	46.0p	45.3p	44.4p	43.5p	42.6p
	CL1	Barcode	100g	N/A	47.0p	46.3p	45.4p	44.4p	43.5p
2nd Class	EBS	Mailmark	100g	N/A	29.2p	28.7p	28.1p	27.5p	26.9p
	CLB	Advanced	100g	37.4p	30.3p	29.8p	29.1p	28.5p	27.9p
	CL4	OCR	100g	N/A	30.0p	29.5p	28.9p	28.3p	27.6p
	CL2	Barcode	100g	N/A	30.5p	30.0p	29.3p	28.7p	28.1p

Prices in this table exclude VAT, which is charged at the standard rate.

Business Mail

Unsorted

Table 3 – Large Letter: Standard unsorted options

Delivery Speed	Option	Product Code	Weight up to and including	Number of items per sales order				
				0-249	250-749	750-1,999	2,000-4,999	5,000+
1st Class	Tariff	STL	100g	83.0p	81.8p	80.5p	78.9p	77.2p
			250g	114.0p	112.3p	110.6p	108.3p	106.0p
			500g	150.0p	147.8p	145.5p	142.5p	139.5p
			750g	211.0p	207.8p	204.7p	200.5p	196.2p
	Account*	UNA	100g	82.0p	80.8p	79.5p	77.9p	76.3p
			250g	113.0p	111.3p	109.6p	107.4p	105.1p
			500g	148.0p	145.8p	143.6p	140.6p	137.6p
			750g	209.5p	206.4p	203.2p	199.0p	194.8p
2nd Class	Tariff	STL	100g	66.0p	64.9p	63.6p	62.2p	60.9p
			250g	93.0p	91.5p	89.7p	87.6p	85.7p
			500g	122.0p	120.0p	117.6p	114.9p	112.5p
			750g	172.0p	169.2p	165.8p	162.0p	158.6p
	Account*	UNB	100g	65.0p	64.0p	62.7p	61.2p	59.9p
			250g	92.0p	90.5p	88.7p	86.7p	84.8p
			500g	119.5p	117.6p	115.2p	112.6p	110.2p
			750g	170.5p	167.8p	164.4p	160.6p	157.2p

Prices in this table exclude VAT, which is charged at the standard rate.

*Available from 27th March 2017.

For further information on the new options for 27 March visit royalmail.com/barcodesavings

Business Mail

Unsorted

Table 4 – Large Letter: Machine-readable unsorted options

Delivery Speed	Option	Product Code	Weight up to and including	Number of items per sales order						
				0-249	250-749	750-1,999	2,000-4,999	5,000+		
1st Class	Mailmark	EBR	100g	N/A	75.8p	74.3p	72.8p	71.2p		
			250g	N/A	108.4p	106.2p	104.0p	101.8p		
			500g	N/A	143.8p	140.9p	138.0p	135.1p		
			750g	N/A	204.4p	200.2p	196.1p	191.9p		
			Advanced*	UNI	100g	82.0p	78.8p	77.2p	75.6p	74.0p
					250g	113.0p	109.3p	107.1p	104.9p	102.7p
					500g	148.0p	144.8p	141.9p	138.9p	136.0p
					750g	209.5p	204.9p	200.7p	196.6p	192.4p
	OCR	CL3	100g	N/A	76.8p	75.3p	73.7p	72.2p		
			250g	N/A	109.8p	107.6p	105.4p	103.1p		
			500g	N/A	145.3p	142.3p	139.4p	136.4p		
			750g	N/A	206.4p	202.2p	198.0p	193.8p		
	2nd Class	Mailmark	EBS	100g	N/A	60.0p	58.7p	57.5p	56.2p	
				250g	N/A	87.1p	85.1p	83.4p	81.5p	
				500g	N/A	116.1p	113.5p	111.2p	108.7p	
				750g	N/A	165.8p	162.1p	158.7p	155.2p	
Advanced*				UNJ	100g	65.0p	61.9p	60.6p	59.3p	58.0p
					250g	92.0p	87.5p	85.6p	83.7p	81.9p
		500g	119.5p		116.5p	114.0p	111.5p	109.0p		
OCR		CL4	750g	170.5p	166.1p	162.6p	159.0p	155.5p		
			100g	N/A	61.0p	59.6p	58.4p	57.1p		
			250g	N/A	88.1p	86.1p	84.3p	82.4p		
500g		N/A	117.6p	115.0p	112.6p	110.1p				
750g		N/A	167.8p	164.0p	160.6p	157.0p				

Prices in this table exclude VAT, which is charged at the standard rate.

*Available from 27th March 2017.

For further information on the new options for 27 March visit royalmail.com/barcodesavings

Business Mail

Low Sort

Table 1 – Full prices and per gram increments

Format	Weight	1st Class [*]		2nd Class ^{**}		Economy ^{**}	
		Full Price	Per Gram Increment	Full Price	Per Gram Increment	Full Price	Per Gram Increment
Letter	0-100g	51.2p	N/A	35.5p	N/A	32.1p	N/A
Large Letter OCR	0-100g	65.3p	N/A	46.2p	N/A	41.2p	N/A
	101-250g	73.8p	N/A	60.1p	N/A	53.3p	N/A
	251-750g	73.8p	0.2128p	60.1p	0.1567p	53.3p	0.1557p
Large Letter Mailmark	0-100g	65.2p	N/A	46.4p	N/A	41.4p	N/A
	101-250g	73.3p	N/A	60.1p	N/A	53.3p	N/A
	251-750g	73.3p	0.1985p	60.1p	0.1519p	53.3p	0.1484p

Prices in this table exclude VAT, which is charged at the standard rate.

Low Sort

Table 2 – Sortation and machine-readable discount

	1st Class [*]		2nd Class ^{**}		Economy ^{**}	
	Direct Items	Product Code	Direct Items	Product Code	Direct Items	Product Code
Letters OCR	19.53%	MXD	19.53%	MXE	19.53%	MXF
Letters Barcode	18.10%	MXM	18.10%	MXN	18.10%	MXO
Letters Mailmark	21.30%	EBA	21.30%	EBB	21.30%	EBC
Large Letters OCR	10.25%	MXD	10.25%	MXE	10.25%	MXF
Large Letters Mailmark	12.45%	EBA	12.45%	EBB	12.45%	EBC

Business Mail

Low Sort

Table 3 – Volume Related Discount^{*}**

Format	Number of Direct Items	1st Class [*]	2nd Class ^{**}	Economy
		Direct Items	Direct Items	Direct Items
Letter	0 – 19,999	0.00%	0.00%	0.00%
	20,000 – 39,999	1.50%	1.50%	1.50%
	40,000 – 79,999	3.50%	3.50%	3.50%
	80,000 – 119,999	4.50%	4.50%	4.50%
	120,000 +	5.30%	5.30%	5.30%
Large Letter OCR	0 – 9,999	0.00%	0.00%	0.00%
	10,000 – 19,999	1.00%	1.00%	1.00%
	20,000 – 39,999	1.50%	1.50%	1.50%
	40,000 – 59,999	2.00%	2.00%	2.00%
	60,000 +	3.00%	3.00%	3.00%
Large Letter Mailmark barcode	0 – 9,999	0.00%	0.00%	0.00%
	10,000 – 19,999	1.50%	1.50%	1.50%
	20,000 – 39,999	3.50%	3.50%	3.50%
	40,000 – 59,999	4.50%	4.50%	4.50%
	60,000 +	5.30%	5.30%	5.20%

*for Business Mail 1st Class only.

**for Business Mail only.

***Volume Related Discounts for Direct items are based on total daily volumes over multiple sales order lines providing all items are posted on the same day; posted from the same posting location (site); posted via the same product and format, and only apply to Direct items (Residue items are not counted towards the calculation).

Low Sort

Table 4 - Trayed Mail Savings

	Saving per item
Low Sort Letters	0.25p
Low Sort Large Letters (up to 10mm thick)	0.60p
Discounts apply after all other discounts (VRDs, sortation etc) are applied but before VAT	

For further information on using trays please visit royalmail.com/traysavings

Business Mail

Calculating the price of your mailing

Step 1: Find the full price for the items you are mailing from Table 1. If the item is Large Letter format and weighs more than 250g, then an incremental price should be added to the full price based on the exact weight of the item. The incremental price is calculated as the incremental weight in grams above 250g multiplied by the gram price increment. The result is rounded to the nearest 1/10th of a penny.

Step 2: Identify the appropriate sortation and machine-readable discount from Table 2.

Step 3: Add to the sortation and machine-readable discount the applicable volume related discount from Table 3.

Step 4: Apply the aggregate discount percentage to the full price to calculate the item price.

Step 5: Multiply the item price by the number of items to calculate the total transaction price excluding VAT.

Worked example

A Low Sort Economy posting of 102,000 Letters Mailmark weighing 80g each.

Step 1: The full price for a Low Sort Economy Mailmark option 80g Letter = 32.1p from Table 1.

Step 2: Sortation and machine-readable discount for Low Sort Letters Mailmark = 21.30% from Table 2.

Step 3: VRD from Table 3 = 4.50%, added to the sortation and machine-readable discount of 21.30% gives total aggregate discount of 25.80%.

Step 4: Price per item = $32.1p \times (100\% - 25.80\%) = 23.8182p$.

Step 5: Total price of mailing = $(23.8182p \times 102,000) / 100 = \text{£}24,294.56$ (excluding VAT).

Trayed Mail Savings:

Letter mailings presented in trays will save 0.25p per item from Table 4 = $(0.25p \times 102,000) / 100 = \text{£}255.00$ (excluding VAT).

Total tray price of mailing = $\text{£}24,294.56 - \text{£}255.00 = \text{£}24,039.56$ (excluding VAT).

Business Mail

High Sort

Table 1 – Full prices and per gram increments

Format	Weight	1st Class [*]		2nd Class ^{**}		Economy ^{**}	
		Full Price	Per Gram Increment	Full Price	Per Gram Increment	Full Price	Per Gram Increment
Product Code		LE1		LE2		LE3	
Letter	0-100g	53.6p	N/A	36.8p	N/A	30.8p	N/A
Large Letter	0-100g	65.9p	N/A	46.8p	N/A	41.7p	N/A
	101-250g	74.1p	N/A	60.8p	N/A	53.6p	N/A
	251-750g	74.1p	0.2007p	60.8p	0.1534p	53.6p	0.1484p

Prices in this table exclude VAT, which is charged at the standard rate.

High Sort

Table 2 – Sortation Discounts

Format	1st Class [*]		2nd Class ^{**}		Economy ^{**}	
	Direct Items	Residue Items	Direct Items	Residue Items	Direct Items	Residue Items
Letter	8.55%	6.05%	8.55%	6.05%	8.55%	6.05%
Large Letter	12.55%	2.55%	12.55%	2.55%	12.55%	2.55%

High Sort

Table 3 – Volume Related Discounts for Direct^{*}**

Format	Number of Direct Items	1st Class [*]	2nd Class ^{**}	Economy ^{**}
		Direct Items	Direct Items	Direct Items
Letter	0 – 19,999	0.00%	0.00%	0.00%
	20,000 – 39,999	1.50%	1.50%	1.50%
	40,000 – 79,999	3.50%	3.50%	3.50%
	80,000 – 119,999	4.50%	4.50%	4.50%
	120,000 +	5.30%	5.30%	5.30%
Large Letter	0 – 9,999	0.00%	0.00%	0.00%
	10,000 – 19,999	1.50%	1.50%	1.50%
	20,000 – 39,999	3.50%	3.50%	3.50%
	40,000 – 59,999	4.50%	4.50%	4.50%
	60,000 +	5.30%	5.30%	5.30%

^{*}for Business Mail 1st Class only.

^{**}for Business Mail only.

^{***}Volume Related Discounts for Direct items are based on total daily volumes over multiple sales order lines providing all items are posted on the same day; posted from the same posting location (site); posted via the same product and format, and only apply to Direct items (Residue items are not counted towards the calculation).

Business Mail

Aggregating volumes on Direct selections to achieve and maximise Volume Related Discounts: In order to reach the VRD threshold on any given posting day, and to maximise the level of VRD obtainable, you can aggregate volumes on Direct selections in 2 ways:

1. You can combine a number of the same product / service level mailings onto one confirmed sales order. You will need to show in the comments field all the job reference numbers or part jobs included on that confirmed sales order. If you do this and then have multiple entries on a single confirmed sales order you must link the individual lines with the appropriate Customer Reference Number (CRN) to maximise your Volume Related Discount.
2. If you are unable to show all mailings for one day on a single confirmed sales order (usually because mailings are at different times) you must put the same Customer Reference Number (CRN) on each confirmed sales order and against each multiple entry. It is not possible to aggregate different sales orders posted on the same day for any unsorted products (Business Mail, Advertising Mail and Business Mail Advanced option).

Any applicable VRDs are calculated at the time you confirm your sales order and will be reflected on the invoice for that date of posting.

High Sort

Table 4 – Volume Related Discounts for Residue***

Format	Number of Direct Items	1st Class*	2nd Class**	Economy**
		Residue Items	Residue Items	Residue Items
Letter	0 – 19,999	0.00%	0.00%	0.00%
	20,000 – 39,999	1.50%	1.50%	1.00%
	40,000 – 79,999	2.50%	2.50%	1.50%
	80,000 – 119,999	2.50%	2.50%	2.00%
	120,000 +	3.00%	3.00%	2.00%
Large Letter	0 – 9,999	0.00%	0.00%	0.00%
	10,000 – 19,999	1.50%	1.50%	1.00%
	20,000 – 39,999	2.50%	2.50%	1.50%
	40,000 – 59,999	2.50%	2.50%	2.00%
	60,000 +	3.00%	3.00%	2.00%

*for Business Mail 1st Class only.

**for Business Mail only.

***Direct selection volumes or multiple posting volumes against any other sales order lines cannot be counted towards the Volume Related Discount calculation for Residue items

High Sort

Table 5 - Trayed Mail Savings

	Saving per item
High Sort Letters	0.25p
High Sort Large Letters (up to 10mm thick)	0.60p

Discounts apply after all other discounts (VRDs, sortation etc) are applied but before VAT

For further information on using trays please visit royalmail.com/traysavings

Business Mail

Calculating the price of your mailing

Step 1: Find the full price for the items you are mailing from Table 1. If the item weighs more than 250g, then an incremental price should be added to the full price based on the exact weight of the item. The incremental price is calculated as the incremental weight in grams above 250g multiplied by the gram price increment. The result is rounded to the nearest 1/10th of a penny.

Step 2: Identify the appropriate sortation discount from Table 2.

Step 3: Add to the sortation discount the applicable volume related discount for Direct (from Table 3) and Residue items (from Table 4).

Step 4: Apply the aggregate discount to the full price to calculate the item prices for Direct and Residue items.

Step 5: Multiply the Direct and Residue prices by the number of items in each category.

Step 6: Add the Direct and Residue values together to calculate the total transaction price excluding VAT.

Worked example

A High Sort 2nd Class posting of 102,000 Large Letters weighing 302g each. 90,000 of these are Directs and 12,000 are Residues.

Step 1: The full price = 60.80p + ((302 – 250) x 0.1534p) = 68.7768p, rounded to the nearest 1/10th of a penny = 68.8p.

Step 2: Direct discount = 12.55%, Residue discount = 2.55% from Table 2.

Step 3: Direct VRD from Table 3 = 5.3%, added to the Direct discount of 12.55% gives a total discount for Direct items of 17.85%. Residue VRD from Table 4 = 1.5%, added to the Residue discount of 2.55% gives a total discount for Residue items of 4.05%.

Step 4: Price of Directs = 68.8p x (100% - 17.85%) = 56.5192p
Price of Residues = 68.8p x (100% - 4.05%) = 66.0136p

Step 5: Price of Directs in mailing = (56.5192p x 90,000)/100 = £50,867.28
Price of Residues in mailing = (66.0136p x 12,000)/100 = £7,921.63

Step 6: Total for this mailing = £50,867.28 + £7,921.63 = £58,788.91 (excluding VAT).

Trayed Mail Savings:

Large Letter mailings presented in trays will save 0.6p per item from Table 5 = (0.6p x 102,000)/100 = £612.00 (excluding VAT).

Total tray price of mailing = £58,788.91 - £612.00 = £58,176.91 (excluding VAT).

Adjustment Charges

Mailmark Adjustment Charges

Fault	Applies to	Flat Fee	Per Item Fee	Note
Missorts	Mailmark Letters	N/A	20.87p	
Missorts	Mailmark Large Letters	N/A	44.51p	
International item as domestic	Mailmark Letters and Large Letters	N/A	£1.20	Adjustment charges only apply when one or a combination of charges result in a charge of £10 or more per eManifest
Unable to resolve	Mailmark Letters	N/A	4.02p*	
Unable to resolve	Mailmark Large Letters	N/A	6.91p*	
Non machine processed	Mailmark Letters	N/A	4.02p*	
Non machine processed	Mailmark Large Letters	N/A	6.91p*	Postcode and Delivery point suffix accuracy adjustment charges only apply if the combined result drops below 90% per eManifest
Postcode accuracy	Mailmark Letters	N/A	7.52p	
Postcode accuracy	Mailmark Large Letters	N/A	14.73p	
Delivery point suffix accuracy	Mailmark Letters and Large Letters	N/A	0.81p	
Missing or incorrect eManifest ID	Mailmark Letters and Large Letters	£25.40	N/A	per eManifest
Unmanifested volume and Duplicates	Mailmark Letters and Large Letters	£25.40	tariff price**	per supply chain
Incorrect SCID	Mailmark Letters and Large Letters	£25.40	N/A	per eManifest
Item ID mismatch	Mailmark Letters and Large Letters	£25.40	N/A	per eManifest

Account and Advanced Charges

Fault	Applies to	Class	Format	Flat Fee	Per Item Fee
Barcode not seen	Unsorted Account	1st Class and 2nd Class	Letters and Large Letters	N/A	1p
Sales Order Under Declared – UK	Account and Advanced	1st Class	Letters	N/A	53p
		2nd Class	Letters		37p
		1st Class	Large Letters		£1.13
		2nd Class	Large Letters		92p
Sales Order Under Declared – International	Account and Advanced		Letters and Large Letters	N/A	£1.20
Not highly machinable	Advanced	1st Class and 2nd Class	Letters and Large Letters		7.7p 3p
Missing Sales Order	Account and Advanced			£25.40	N/A
Incorrect Sales Order	Account and Advanced			£25.40	N/A

Prices in these tables exclude VAT, which is charged at the standard rate.

Full details of the Mailmark adjustment framework are available at royalmail.com/mailmark

*The total amount charged for these faults will not exceed the price of the next available service.

**The difference in price between the volume declared versus the volume submitted.

Adjustment Charges

Machine Readable Adjustment Charges

Fault	Applies to	Flat Fee	Per item fee	Note
Low volume faults	Sorted	£25.40	N/A	per posting
Medium volume low impact faults	Sorted	£25.40	0.1p	0.1p x volume of posting
Medium volume high impact faults	Sorted	£25.40	adjustment	10% of posting adjusted
High volume low impact faults	Sorted and unsorted	£25.40*	1.0p	1.0p x volume of posting
High volume high impact faults	Sorted	£25.40	adjustment	100% of mailing adjusted
Delivery point suffix accuracy	Sorted	N/A	0.5p	0.5p x volume of posting
Incorrect licence design	BMA on account	£25.00	N/A	per month

Prices in this table exclude VAT, which is charged at the standard rate.

*Fee applies to sorted machine-readable mail only.

Full details of the Low/High machine readable faults are available in the Quick Guides at royalmailtechnical.com

Other Adjustment Charges

Fault	Applies to	Flat Fee	Per item fee	Note
Presentation errors	Sorted	£25.40	N/A	per posting
Incorrect labels/bag ties	Sorted	£25.40	20p	per label or tie
Incorrect cage cards	Sorted	£25.40	25p	per card used
Storage costs	Sorted	£25.40	25p	per cage per day
Overweight bags/bundles/trays	Sorted	£25.40	65p	per bag/tray generated
Overweight cages/Yorks	Sorted	£25.40	65p	per Cage/York generated
Minimum average per selection	Sorted	£25.40	adjustment	100% of mailing
Bulk surcharges	Unsorted	N/A	30p*	per item
Response specification	Response	N/A	30p	per item
Response specification	Response	£25.00	N/A	per licence per month
No sales order or posting cheque	Sorted and unsorted	£25.40	N/A	per posting
Incorrect Sales Order	Sorted and unsorted	£25.40	N/A	per cheque

Prices in this table exclude VAT, which is charged at the standard rate, except for Bulk surcharges.

*Bulk surcharges are exempt from VAT.

